

LAKE ST. CLAIR WALLEYE ASSOCIATION

P.O. BOX 130

ST. CLAIR SHORES, MI 48080

Scan with your Smartphone



YOUR DUES EXPIRE AT THE END OF THIS MONTH



To Check Out  
Our Website

PRINTED ON RECYCLED PAPER

FIRST CLASS  
MAIL

OFFICIAL NEWSLETTER OF THE LAKE ST. CLAIR WALLEYE ASSOCIATION



# WALLEYE WORLD

DEDICATED TO THE PRESERVATION OF MICHIGAN'S WALLEYE FISHERY (SINCE JULY, 1976)

March 2015

<http://www.lscwa.net>



Left to Right: Jerry Jr., Jerry Sr., Rich Benson and Ken Fox.



The Offshore table was very busy.

## Report From February General Membership Meeting

by David A. Wilemski

Well I must say that the February 2015 meeting was one of the best in a long while. Keith Krych videotaped it so it will be shown at a later date. For all of you who were not present for the Feb 21 meeting "you missed a chance to better your walleye fishing success".

The (Main Event) guest speakers were Jerry Fox Sr. and his two sons Jerry Jr. and Ken.

The three Foxes have fished the Walleye Pro Circuit for many years. They have won many of these events and made quite a bit of money. Jerry Fox Sr. was our club president for ten years in a row. Our monthly 'Walleye World' newsletter is not big enough for me to list all of Jerry's accomplishments and contributions to the LSCWA.

Also, it would take me several pages to relate all the valuable information given at this particular seminar. It would also not be fair to give those who stayed home the same info that was learned by the members and guests that braved the cold weather to show up.

You do not have to be a LSCWA member to attend any one of our 11 monthly meetings. Sign in as a guest, pull up a chair and check us out once, twice or more times. You will eventually join the fastest growing (family) 501c3 fishing club around.

OK... I will give you one tip we all learned from that seminar: "A stiff rod is not better than a whippy one for walleye fishing with Off-Shore Planner Boards. Show up at the March meeting and ask any fishing person who attended the February meeting to explain this.

LAKE ST. CLAIR WALLEYE ASSOCIATION

(586) 778-0480

**LSCWA EXECUTIVE BOARD**  
 President ~ Richard Benson  
 Vice President ~ Jerry Comfort  
 Financial Secretary ~ Bob Barnes  
 Recording Secretary ~ Tim Muir  
 Membership Secretary ~ Don Murray

**BOARD OF DIRECTORS**

Richard Koch (15)	Jim Lease (16)
Keith Krych (15)	Al McMurray (16)
Dave Marcelewski (15)	John Roodbeen (16)
Jeff Regulski (15)	Karl Sauners (16)
Alex Vitek (15)	Mike Smith (16)

**ALTERNATES** – Paul Imbrunnone & Ron Pisarski

**FIELD REP** – Stan Bydlos

**OB MOTOR RAFFLE** – Jerry Comfort

**Kids Events & Derby Weigh-Ins** – Jeff Regulski

**Merchandise** – Mike Smith

**CALENDAR OF EVENTS**

Mar 17 ..... St. Patrick's Day

Mar 18 ..... General Meeting ..... Multi Workshops  
 Come in and learn something new

Mar 25 ..... Breakfast Get-2-Gether South Side Grill  
 2769 Nine Mile btw Ryan and Dequindre 8:30 am

April 5 ..... Easter Sunday

Apr 15 ..... General Meeting Swap-n- Shop  
 Bring your old or slightly used fishing equipment and sell or trade.

Apr 19 ..... April Derby weigh-in at Sportsman's Direct btw 3 and 5

Apr 22 ..... Breakfast Get-2-Gether Buck's Diner  
 8927 Dixie Hwy in Fair Haven before Swan Creek 8:30 am

May 1 & 2 ..... MUCC Youth Camp Clean Up  
 Need Volunteers

**GENERAL MEMBERSHIP MEETING**

**WEDNESDAY ~ 7:30 P.M.**

*March 18, 2015*

**FOR ALL MEMBERS IN GOOD STANDING**

(Walk-ins Welcome)

**LAKELAND BANQUET & EVENT CENTRE**

21801 Nine Mile Rd. (East of Harper) St. Clair Shores, MI 48080

*Next Reg. Meeting April 15, 2015*

**Log onto our website to find out what is  
 happening in and around the Club**

**www.lscwa.net**

The **WALLEYE WORLD** is the official monthly newsletter of the Lake St. Clair Walleye Association (a 501c3 non-profit organization). We welcome all written/photo contributions from the members. Written/photo contributions can be submitted to jlease357@hotmail.com. All written or photo contributions are the property of the LSCWA Walleye World and subject to edit. We reserve the right to refuse any material. Views and opinions expressed in the Walleye World are those of the author and do not necessarily represent the views and opinions of the LSCWA, its members, or its advertisers. The LSCWA, the Walleye World or its publisher assumes no liability with respect to the use of information contained herein. 900 copies printed each month (1,200 for Jan. & None for Nov.)

**EDITOR:** Jim Lease. Email or phone me with your articles. jlease357@hotmail.com or phone 586-722-3330.

*Club Reporter: David A. Wilemski*

**CONSERVATION PLEDGE**

I give my pledge as an American to save and faithfully defend from waste the natural resources of my country, its air, soil and minerals, its forests, waters and wildlife.

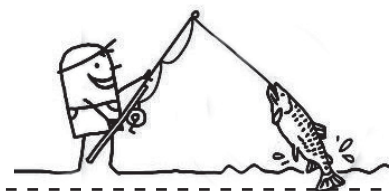

**CUT OUT COUPON & MAIL**

**APPLICATION FORM  
 AND CHANGE OF ADDRESS**  
 Make check or money order payable to:  
**LAKE ST. CLAIR WALLEYE ASSOCIATION**

**P.O. BOX 130**

**St. Clair Shores, MI 48080**

**PLEASE PRINT**

CHECK HERE IF THIS IS AN ADDRESS CHANGE

NAME \_\_\_\_\_

ADDRESS \_\_\_\_\_

CITY \_\_\_\_\_ STATE \_\_\_\_ ZIP \_\_\_\_\_

PHONE \_\_\_\_\_

**New Initiation Fee \$10.00**

**Renewal**

**Single Membership \$40.00**

**Senior Citizens \$30.00**  
 Includes Spouse

**Family Membership \$45.00**  
 Includes Spouse & Children to  
 16 years

**Senior Family \$35.00**  
 Includes Spouse &  
 Grandchildren to 16 years

**Junior \$15.00**

Children up to 16 Years Old

How did you hear about us? \_\_\_\_\_

\_\_\_\_\_

## President's Corner

by Richard Benson

March is here, winter's icy grip begins to loosen as the days grow longer and spring takes over. Soon, the lakes will melt and the walleye begin their spring runs into the rivers and streams and walleye fever begins! Jigging, trolling, casting and from fishing from shore, open water fishing will soon be here and the LSCWA is preparing for another great year of fishing.



In March we will have our annual mini-seminars during our monthly meeting. Here, experienced members share tips and tactics to help you catch your limit. Then in April, we have our annual swap shop, where members bring fishing gear to sell and trade, new-old-unused...whatever, what man's junk is another's treasure. April also marks the return of our derbies and also a professional tournament in St. Clair Shores. This is just the start of a busy fishing season, come on out and see what else the LSCWA has in store, it's going to be a BIG year!

Good fishing,

Rich Benson, President

## BINGO

Prizes are mounting every week  
Come on out give it a try and  
support your club. Prizes total  
**\$2200** every night or more!

20791 E. 13 Mile Rd  
Roseville, MI 48066

Sundays

Doors open at 4PM • Play at 6PM

We are always looking for  
volunteers..

**See Rich at our meetings or events.**

## Trade-a-Trip 2015

by Keith Krych

This years Trade-a-Trip is set for the Battle Creek Steelheaders to come here May 2nd and 3rd. We need boaters to take the Steelheaders out on the river and catch some tasty walleyes for them. We also are having the traditional fish fry dinner with all the trimmings, Saturday the 2nd around 4pm at the Rose Clair Eagles Hall, 29500 Little Mack Ave in Roseville, (586) 775-5860. All club members are welcome for the dinner!

On Sunday your crew has the option to fish and go right home, or for those that want to participate, on Sunday we will be also have the Rec Bowl Tournament going on. You can sign-up for the fun tournament and go to the weigh-in. Then enjoy another dinner and have a chance at some cash prizes.

The Walleye club will be going to St. Joe May 16th and 17th. The fishing should be great that time of year. The Steelheaders are also having a tournament that weekend and we have an opportunity to fish in that one with them.

Here are a list of some local Motels:

### **Silver Beach Hotel**

100 Main Street  
St. Joseph

866-514-6232 OR 269-983-7341

### **Holiday Inn Express Hotel & Suites St Joseph**

3019 Lake Shore Drive  
St Joseph, MI 49085  
1(269) 982-0004

### **Super 8 Motel**

1950 E Napier Ave  
Benton Harbor, MI 49022  
1(269) 926-1371

### **Motel 6 Benton Harbor**

2063 Pipestone Rd  
Benton Harbor, MI 49022  
1(269) 925-5100



# StructureScan

## What Is It and How to Use It

by Keith Krych

The newest technology to hit the fishing market in the last few years is StructureScan. It combines High Definition Side Imaging and Down Scanning in a unit that can find fish in a way that a conventional SONAR will not.

The DownScan sonar “cone” is very narrow and further out side to side than conventional sonar, giving a very detailed view of what’s under the boat. Side Imaging is also a very narrow beam of sound projected out up to 240 feet to the side of the boat. Letting you see objects on the bottom and suspended fish in the water column.

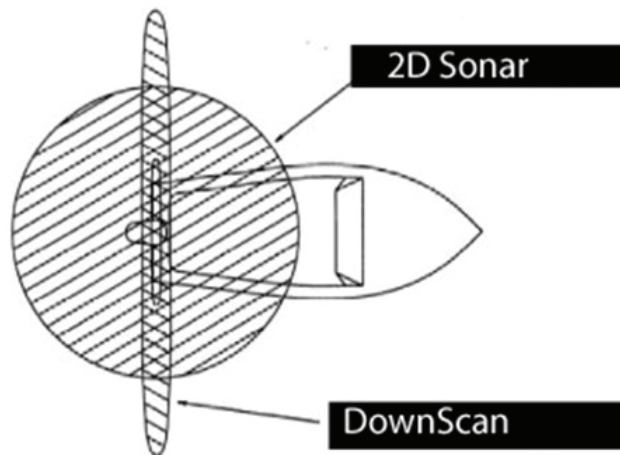

So how do you use it? Let me explain how I used it on the Detroit River last spring.

I like to use a split screen with side imaging / down scan / conventional sonar and GPS on my screen at the same time. As an example, when I leave the Delray launch, I start scanning right away. I'll check out the Core of Engineers area just north of the launch. StructureScan works best at speeds under 10mph, and can reach out over 100 feet on both sides of the boat, with great definition. So instead of zigzagging in a pack of boats to look for fish with conventional SONAR, I can scan outside a pack of boats at 10mph and see if there are any fish and what size they are. Cool, right! If there are none there, or they are small, I'll move to another area instead of wasting prime fishing time on that spot.

If you see a nice concentration of fish, or good sized ones, I'll drop a way point above the line where the fish are located. You are able to do this by moving the cursor just above the fish on the StructureScan screen and hitting a way point. Pretty cool! By the way, I have found that most fish line up in a row on the bottom of the river, by using this side imaging system you can see this. You have to be right on the line to catch them. This system it's simple to do.

Once you have caught the fish in an area that you have marked on the StructureScan, leave. You don't waste time going over and over an area expecting the “bite” to pick up when you know the fish are no longer there anymore.

Using this technology you stay on fish all the time, going from fish holding spot to fish holding spot! You don't waste time fishing unproductive areas.

Next month we will talk about using StructureScan on the lake and how to use it there.

Until then, keep your lines in the water.

# LSCWA PHOTO PAGE



**Hey, that's not  
oatmeal**

## **GUNFLINT WALLEYE**

(Original recipe modified from the Gunflint Lodge recipe.)

- 1/4 cup butter
- 2 - 3 large garlic cloves, finely chopped (I used minced garlic in a jar)
- 1 - 2 teaspoons fresh lemon juice (I used Realemon)
- 2-1/2 lbs. boneless, skinless walleye fillets
- salt & freshly ground pepper (I used sea salt)
- 3/4 cup Parmesan cheese
- 1 cup fine dry breadcrumbs (I used Progresso Italian Style)

### **INSTRUCTIONS**

1. Preheat oven to 450 degrees
2. Spray a 15 x 10 x 1 inch baking pan with nonstick cooking spray
3. In a small saucepan, melt butter and stir in garlic and lemon juice.
4. Rinse walleye fillets and cut into 6 serving sizes if necessary
5. Place walleye fillets in pan and sprinkle all over with the Parmesan cheese
6. Cover cheese sprinkled fillets with the bread crumbs.
7. Drizzle the fish with the garlic-lemon butter. (If desired, fish may be prepared to this point, covered, and refrigerated up to 1 hour before cooking the fish.)
8. Bake in 450 degree oven for 10 to 12 minutes or until the fish flakes easily.
9. When fillets are flaky and golden brown, transfer them to a warmed serving platter. You may garnish with green onion if you like.

Enjoy!

*Terri Smith*



## Fact Check

By David A. Wilemski

Many of us wasted lots of money the past several months trying to win 100 to 500 million dollar Lotto jackpots on Power-Ball, Mega-Millions, etc.

Well I just crunched the numbers and guess what? Your chances of winning a brand new 9.9 Honda 4- cycle kicker motor are many thousands of times better. See Dave Wilemski or Marylyn Krych for tickets. (Jerry Comfort is busy guarding your new motor).

## Merchandise Table

By Marialaina Benson

With spring on its way I plan on having a few items to get that boat ready for the first launch, the rods ready for the first cast as well as other useful items for you. Thank you for your continued support.



## MUCC 2015 Youth Camp

by Tim Muir

The LSCWA sends two kids to the MUCC Youth

Camp on Cedar Lake for a great outdoors learning experience and now we need those kids names to be selected.

Preference is given to ages 9-11 for the Inland Fishing Camp, June 21st-26th. The requirements for consideration are that the kids be family members of a current LSCWA member. The MUCC camp is a great time that will build memories to last forever. Please see me at the March general membership meeting with any questions or if you have someone wanting to go

Or you can call me at 586-354-0145

or email at [tmuirjr@gmail.com](mailto:tmuirjr@gmail.com).

The drawing will be held at the March board of directors meeting.



## Paraprosdokians

1. In filling out an application, where it says, "In case of emergency, Notify: I put 'DOCTOR'.
2. Women will never be equal to men until they can walk down the street with a bald head and a beer gut, and still think they are sexy.
3. You do not need a parachute to skydive. You only need a parachute to skydive twice.

---

## Puns for Educated Minds

1. A dog gave birth to puppies near the road and was cited for littering.
2. The fattest knight at King Arthur's round table was Sir Cumference. He acquired his size from too much pi.
3. A grenade thrown into a kitchen in France would result in Linoleum Blownapart.



# February 2015 Treehouse Senior Get 2 Gether

by David A. Wilemski

February 25<sup>th</sup> at 8:30 AM was a fairly good turn-out for our monthly breakfast club get-together. We had 8 hungry individuals participate. **Straw Berry Fields** on 23 Mile Road in Chesterfield has a great selection of tasty meals. Waitress 'Debbie' was excellent at serving our meals, taking our picture and picking the winning tickets.

Left to right, front we have: Curtis Patton, Joann Koch, Dave Wilemski (standing), Back Bob Peterson, Richard Koch, Dale Billings, Judi Ramin and (in-uniform) Eugene Ramin. We were all laughing in the picture because a lady nearby jumped into the previous picture and made a scary face which broke up Debbie our photographer / waitress.

Editor Jim Lease was absent and probably still celebrating his birthday of a few days earlier.

**Joann** won a Beacon Light laptop computer with leather carrying case. **Dale** won a new 20 foot 3/8" boat mooring line. The mooring line is for a 40 footer so Dale will have to upgrade his boat. **Eugene** won the portable back scratcher. **Curtis** did not charge any fee for using his lucky hat in the free raffle.

Discussions centered on ice fishing; why **Cookie** was not having his normal oatmeal breakfast and why I had to leave early because of my puppy 'Seger's big operation the day before.

After our get-2-gether, Cookie & Joann went Pike spearing.

Rich Ignatowski  
Owner

Custom made here in the Thumb of Michigan

3740 Oakland • Caseville, MI  
Cell: 1-989-553-1303  
Email: walleyeatsag@yahoo.com

**BRIAN'S BLUE WATER BAIT**  
LIVE BAIT & TACKLE  
Hunting & Fishing Licenses

- Silver Streak
- Bomber - Rapala
- Shimano - Daiwa
- Berkley - Penn

8089 Dixie Hwy., Suite E  
Fair Haven, MI 48023  
(Next to DNR Public Launch)

**BRIAN & RENEE KING**  
Ph: (586) 725-1448  
Fax: (586) 725-7253

**Joe's Bait & Tackle**

Live Bait, Large Tackle Selection,  
Michigan & Canadian Licenses,  
Pet Food, Pool & Spa Supplies,  
Wild Bird Seed

39610 Jefferson Ave.,  
Harrison Twp., MI  
48045  
586.469.3517

Lynn Caldwell, Realtor,  
Sine & Monaghan Realtors, Real Living  
18412 Mack Ave.  
Grosse Pointe Farms, MI 48236  
Direct: 586.294.5055  
Office: 313.884.2293  
Email: caldwel@TurnTheKeys.com  
Web Site: TurnTheKeys.com  
Waterfront Specialist

As a Property Owner in Your  
Neighborhood, I have a Vested  
Interest in Your Market Area

**MURPHY'S TAXIDERM**  
fish mounts - fish carvings  
graphite replicas

Doug Murphy, Artist  
517.548.6857  
2885 Black Eagle Ridge  
Howell, Michigan 48843

**ANGLER'S**  
Outfitters

FISHING TACKLE - ARCHERY - PET FOOD  
BIRD SEED - LIVE BAIT

1426 Oakland Ave., St. Clair, MI  
Owners: Bill & Theresa Barrons  
810-329-2253

**LOOK -N- BACK CHARTERS**  
"Sport Fishing in Comfort & Ease"  
CAPTAIN JIM BRATTON

100 Ton Master  
U.S. Coast Guard License  
Boat Inspected by the  
State of Michigan  
Michigan Charter Boat Assoc. Member  
Phone (586) 469-6989  
Cell (586) 292-1720

Uncle Henry's  
Gourmet Meats, LLC

Boneless Venison Processing \$75.00  
(Vacuumed Package & Labeled)

We'll Smoke Your Meats & Fish

Jerky, Sausage, Snack Sticks  
7 days a week

248 740 8755 • 1331 piedmont Dr. Troy, MI 48083

**Detroit's #1 Bait & Tackle Dealers**  
Live Bait • Rods • Reels • Lures • All Your Fishing Needs

Hours: M-F 6am to 8pm Sat/Sun 5am to 8pm

**Moe's Bait & Tackle**  
14712 E. Jefferson  
Detroit, MI 48207  
313.824.5222

**Big Moe's Bait & Tackle**  
6440 E. Jefferson  
Detroit, MI 48207  
313.259.1176

**Sportsmen's DIRECT**  
Targeting Outdoor Innovation

**Live Bait, Tackle & Much More**  
36072 Jefferson Ave, Harrison Twp, MI 48045  
Hours adjusted seasonally - please call for current hours  
Phone: 586.741.6052  
Fax: 586.741.6053  
store@sportsmensdirect.com  
www.sportsmensdirect.com

bp

**NAUTICAL MILE bp, LLC**  
Live Bait - Tackle  
US/Canadian Fishing Licenses  
23800 Jefferson St. Clair Shores, MI 48080  
(586) 498-7650  
Sun - Tues 6am/10pm Wed - Sat 6am/11pm

**LUREWHORE**  
Custom Painted Lures  
John Latham  
Algonac, MI  
buy /sell / trade new and used fishing tackle  
Phone: 810-580-9579  
LureWhore@Comcast.net

810-560-9415

**Grosso Trucking & Supply**

10015 Marine City Hwy.  
Fair Haven, MI 48023

STEVE  
(586) 725-2935  
Fax (586) 725-4153

Jim Sitkewicz

**Eyelimator Trolling System**

1309 S. Carter Rd.  
Midland MI, 4862  
(989) 662-0336 • (989) 860-5723  
weekender23@charter.net

35229 23 Mile Rd  
New Baltimore  
586-725-1255

51292 Romeo Plank  
Macomb Twp.  
586-786-7599

**The Country Inn**

35756 Van Dyke  
Sterling Heights  
586-826-9100

**COMFORT CHARTERS**  
Lake St. Clair / Detroit River / St. Clair River

**Jerry Comfort • 586-482-0026**  
jercomfort@aol.com



(586) 792-2560  
Fax: (586) 792-8731

### RING & PINION SHOP

"Put Your Rear End In Our Hands"

Sales and Service

36180 Groesbeck Hwy.  
Clinton Twp., Michigan 48035

Outboard  
Specialist



Certified  
Sales & Service

### ROSE MARINE SERVICE, INC.

JOHNSON • Evinrude

MERCURY • YAMAHA

Bill & Kandy

Ph: (586) 716-9600  
Fax: (586) 716-4422

7321 Dyke Rd.  
Algonac, MI 48001

Across from Selfridge DNR  
Boat Ramps  
see back www.



Lk St. Clair Bluegill to Muskie

28955 WILLIAM P ROSSO HWY  
CHESTERFIELD TWP, MI 48047

Fax 586.601.2747

Phone 586.949.9223

Bait . Full Tackle . Licenses . Charters  
Gas . Beer & Wine . Snacks & Pop  
Wells . Drive Up Dock Service  
Cabin, Ice Shanty & Boat Rentals  
E-mail . anglerspointmarina@yahoo.com



989-738-5600

Fax: 989-738-5820

P.O. Box 86  
Port Austin, MI 48467

www.offshoretackle.com

(810) 794-1810

STATE & FEDERAL  
LICENSED



PAUL BURCZYCKI  
4566 Pte. Tremble (M-29)  
Algonac, MI 48001

CERTIFIED SCALE  
OLD WORLD CRAFTSMANSHIP  
NEW WORLD TECHNIQUES

### Metro Party Shoppe & Bait Shop



Beer • Wine • Liquor  
Lotto • Deli • Pizza

Freshest Live Bait & Supplies



Phone: 586-463-2173

Fax: 586-463-0706

Ed Mroz  
www.Deadliestkatch.com

**Deadliest Katch Lures & Tackle**  
Eye Kandy Lures & Spoons



20366 Palms dr.  
Clinton Twp. MI 48036

586-822-4699

Deadliestkatch@aol.com  
Facebook.com/Deadliestkatch

### P.G.A. RV • MARINE • AUTO COLLISION

FIBERGLASS REPAIRS & REFINISHING

GARY PATCHAK

32393 LAKEPOINT  
CHESTERFIELD, MI 48047  
WWW.PGACOLLISION.COM

586-725-1863  
FAX 725-3148

- Live Bait
- Sports Supplies
- Apparel



BAIT & TACKLE

5460 Pointe Tremble  
Pearl Beach, MI

(810) 512-4479  
Fax: (810) 512-4501



Matthew Mordan  
Multi-Line Agent

191 North Avenue  
P.O. Box 1209  
Mt. Clemens, MI 48046  
mmordan@actiongroup.net

1-800-550-4790  
(586) 868-2440  
Cell (586) 634-9171  
Fax (586) 868-2441  
www.actiongroup.net



2769 E. Nine Mile Rd.  
Warren, MI 48091

CONEY ISLAND

586-754-2940



Home Inspections

Illuminating Your Home Purchase  
Better Business Bureau Accredited Business

**David A. Wilemski**  
Certified Home Inspector  
Licensed Builder for Over 30 Years

47444 Forton St.  
PO Box 577  
Chesterfield, MI 48047

(586) 292-6143  
dave\_wilemski@juno.com

www.beaconlighthouseinspections.com



### MOZZARELLA FELLAS

Family Owned & Operated  
To experience "Traditional Italian Home Cooked" dinners  
and specials prepared by experienced Chefs, stop by today  
and enjoy the many delicious flavors that await you.  
We Cater All Events!  
(586) 293-5555

33323 Harper at 14 Mile Rd., Saint Clair Shores, MI.



**MINN-KOTA**

AUTHORIZED SERVICE CENTER  
Stocking a Full Line of Parts  
- MOST REPAIRS DONE THE SAME DAY -  
**COASTLINE POWER & LIGHTING**  
586-648-6287  
Servicing MINN KOTA Motors Since 2003

8859 Dixie Hwy. (M-29)  
Fair Haven, MI 48023

John & Sue Cornish  
Alex Cornish



Building confidence with professional services and competitive pricing since 1966  
... one customer at a time.

Full Color Printing • Color Copies  
Brochures • Newsletters • Flyers  
Booklets • Forms • Business Cards  
Postcards • Graphic Design • Laminating  
Digital Files Accepted • Fast Service!

Quality Printing at Competitive Prices Since 1966

## LAKESIDE FISHING SHOP

"YOUR ONE STOP FISHING SHOP"

Visit us online @ [www.lakesidefishingshop.com](http://www.lakesidefishingshop.com)

2511 Jefferson (Corner 10 Mile & Jefferson)

(586) 777-7003 • Fax: (586) 777-1730

Hours: M-F 6-7:30 Sat: 6-6 Sun: 6-5

American • Canadian • Walpole Licenses Available

**10% Off**  
All Nets

Sunglasses  
**15% Off**

**10% Off**  
Live Target  
Lures

Buy 4 Harnesses  
Get 1 Free  
Equal Price

FISHING REPORT (586) 777-7008

Email: [info@lakesidefishingshop.com](mailto:info@lakesidefishingshop.com)